

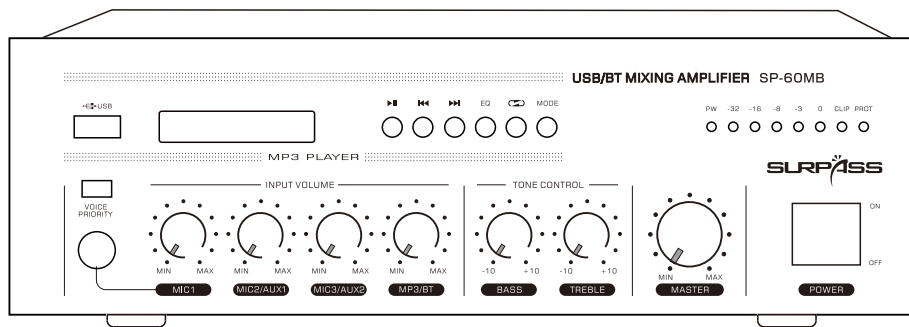

# User Manual



## USB/BT MIXING AMPLIFIER SP-60MB

Thank you for purchasing the **USB/BT Mixing Amplifier**.  
 Please carefully follow the instructions in this manual to ensure long, trouble-free use of the equipment.

**Packaging Contents**

USB/BT amplifier.....1  
 User manual.....1  
 AC power cord.....1  
 Antenna.....1  
 Audio cable.....1

**SAFETY PRECAUTIONS**

- ※ Be sure to read the instructions in this section carefully before use.
- ※ Make sure to observe the instructions in this manual as the conventions of safety symbols and messages regarded as very important precautions are included.
- ※ We also recommend you keep this instruction manual handy for future reference.



The lightning flash with arrowhead symbol, within an equilateral triangle, is intended to alert the user to the presence of uninsulated "dangerous voltage" within the product's enclosure that may be of sufficient magnitude to constitute a risk of electric shock to persons.



The exclamation point within an equilateral triangle is intended to alert the user to the presence of important operating and maintenance (servicing) instructions in the literature accompanying the appliance.

**WARNING**

**When Installing the Unit**

- ※ Do not expose the unit to rain or an environment where it may be splashed by water or other liquids, as doing so may result in fire or electric shock.
- ※ Use the unit only with the voltage specified on the unit. Using a voltage higher than that which is specified may result in fire or electric shock.
- ※ Do not cut, kink, otherwise damage nor modify the power supply cord. In addition, avoid using the power cord in close proximity to heaters, and never place heavy objects -- including the unit itself -- on the power cord, as doing so may result in fire or electric shock.
- ※ Be sure to replace the unit's terminal cover after connection completion. Because high voltage is applied to the speaker terminals, never touch these terminals to avoid electric shock.
- ※ Be sure to ground to the safety ground (earth) terminal to avoid electric shock. Never ground to a gas pipe as a catastrophic disaster may result.
- ※ Avoid installing or mounting the unit in unstable locations, such as on a rickety table or a slanted surface. Doing so may result in the unit falling down, causing personal injury and/or property damage.

**When the Unit is in Use**

※ Should the following irregularity be found during use, immediately switch off the power, disconnect the power supply plug from the AC outlet and contact your nearest dealer. Make no further attempt to operate the unit in this condition as this may cause fire or electric shock.

· If you detect smoke or a strange smell coming from the unit.

· If water or any metallic object gets into the unit.

· If the unit falls, or the unit case breaks.

· If the power supply cord is damaged (exposure of the core, disconnection, etc.)

· If it is malfunctioning (no tone sounds.)

※ To prevent a fire or electric shock, never open nor remove the unit case as there are high voltage components inside the unit. Refer all servicing to your nearest dealer.

※ Do not place cups, bowls, or other containers of liquid or metallic objects on top of the unit. If they accidentally spill into the unit, this may cause a fire or electric shock.

※ Do not insert nor drop metallic objects or flammable materials in the ventilation slots of the unit's cover, as this may result in fire or electric shock.

**CAUTION****When Installing the Unit**

※ Never plug in nor remove the power supply plug with wet hands, as doing so may cause electric shock.

※ When unplugging the power supply cord, be sure to grasp the power supply plug; never pull on the cord itself. Operating the unit with a damaged power supply cord may cause a fire or electric shock.

※ When moving the unit, be sure to remove its power supply cord from the wall outlet.

Moving the unit with the power cord connected to the outlet may cause damage to the power cord, resulting in fire or electric shock. When removing the power cord, be sure to hold its plug to pull.

※ Do not block the ventilation slots in the unit's cover.

Doing so may cause heat to build up inside the unit and result in fire.

※ Avoid installing the unit in humid or dusty locations, in locations exposed to the direct sunlight, near the heaters, or in locations generating sooty smoke or steam as doing otherwise may result in fire or electric shock.

**When the Unit is in Use**

※ Do not place heavy objects on the unit as this may cause it to fall or break which may result in personal injury and/or property damage. In addition, the object itself may fall off and cause injury and/or damage.

※ Make sure that the volume control is set to minimum position before power is switched on.

Loud noise produced at high volume when power is switched on can impair hearing.

※ Do not operate the unit for an extended period of time with the sound distorting.

This is an indication of a malfunction, which in turn can cause heat to generate and result in a fire.

※ Contact your dealer as to the cleaning. If dust is allowed to accumulate in the unit over a long period of time, a fire or damage to the unit may result.

※ If dust accumulates on the power supply plug or in the wall AC outlet, a fire may result.

Clean it periodically. In addition, insert the plug in the wall outlet securely.

※ Switch off the power, and unplug the power supply plug from the AC outlet for safety purposes when cleaning or leaving the unit unused for 10 days or more.

Doing otherwise may cause a fire or electric shock.

**LIMITED WARRANTY**

We warrant that the hardware products it manufactures will be free from defects in materials and workmanship.

The warranty term, beginning on the date of invoice, is one year for Parts replacement, two years for parts repair and six months on accessories.

This warranty does not cover damage or failure caused by alterations, mishandling, abuse, misuse, neglect, accident or resulting from any cause other than a product defect.

In case of defects in material and workmanship under normal use and conditions, we will replace or repair products covered under this limited warranty that are returned to our facility.

To request warranty service, you must contact our international sales team within the warranty period, ship the products back to us in their original or equivalent packaging (freight prepaid). If we repair or replace a product, its warranty term is not extended.

**DISCLAIMER**

Information contained in this manual is subject to change without prior notice and does not represent a commitment on the part of the vendor. We shall not be liable for any loss or damages whatsoever arising from the use of information or any error contained in this manual.

It is recommended that all services and repairs on this product be carried out by us or its authorized dealer.

This product must only be used for the purpose it was intended by the manufacturer and in conjunction with this operating manual.

We cannot accept any liability whatsoever for any loss or damages caused by service, maintenance or repair by unauthorized personnel, or by use other than that intended by the manufacturer.

## DESCRIPTION &amp; FEATURE

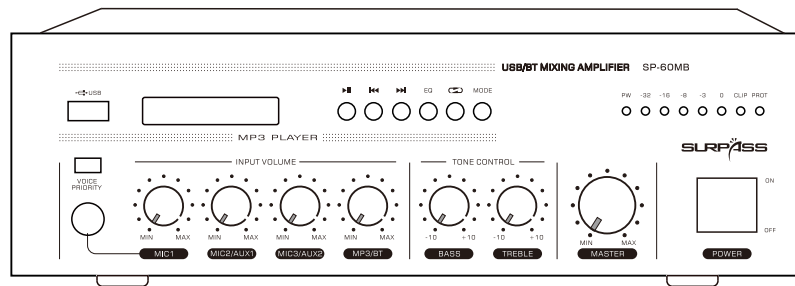

This Compact USB/BT Mixing Amplifier provides 60 watts of output power with with bluetooth, intergral USB audio player power, and 5 inputs including 3 balanced MIC (MIC1 has another port of 6.35mm jack on front panel), 2 unbalanced AUX, each one has individual volume control.

Features include a button "VOICE PRIORITY" that the MIC1 can be set with priority overriding the other inputs. Separate controls for treble bass and allow adjustment of tonal quality, TREBLE ontrols the amount of cut or boost of treble frequencies above 10 kHz. BASS ontrols the amount of cut or boost of bass frequencies below 100 Hz. Colorful indicators on front panel include the ones of power, signal, peak and protection.

This amplifier is compatible with 70V, 100V, 4-ohm, and 8-ohm speaker systems, it is a hugely versatile component of your background music and paging system.

- ※ Built-in Bluetooth receiver and USB player.
- ※ 70/100-volt and 4/8 ohms( $\Omega$ ) output loads.
- ※ SMT circuit boards with highly stable performance.
- ※ Powerful amplifier tubes.
- ※ Three microphone jacks, on rear panel the MIC1 has 48v phantom power.
- ※ Mic 1 has priority over the inputs.
- ※ High-definition display for the working status of playing programme.
- ※ Individual volume controller for inputs, and master volume controller for all.
- ※ BASS and TREBLE tone controllers.
- ※ Complete protection is provided for output short circuit, overload, high temperature, peak current limiters.

FRONT PANEL

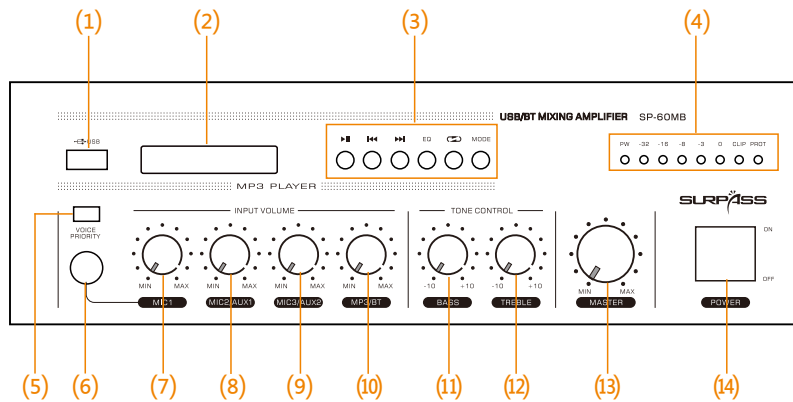

- (1) **USB INPUT INTERFACE:** Allows you to play USB disk.
- (2) **SCREEN:** Displays the working status of playing programmes.
- (3) **MP3 CONTROLLERS:**
  - ⏪ This button shall return to the previous song. Or keep pressing to reduce the volume.
  - ⏩ This button shall skip to the next song. Or keep pressing to increase the volume.
  - EQ** To create 6 different equalizer effects.
  - 🔄 To press this button to play the song repetitively.
  - MODE** To select the mode between USB and bluetooth.
- (4) **LED INDICATORS:**
  - PW** Lights red when the amplifier is powered on.
  - 32/-16/-8/-3/0** Flashes according to the audio level.
  - CLIP** Lights yellow when amplifier is overdriven.
- (5) **VOICE PRIORITY:** To press this button to provide Auto-Mute function for MIC 1.
- (6) **MIC1:** 6.35mm microphone input jack.
- (7) **MIC1:** Microphone 1 input volume control.
- (8) **MIC2/AUX1:** Allows you to control the volume of MIC2 or AUX1 input.
- (9) **MIC3/AUX2:** Allows you to control the volume of MIC3 or AUX2 input.
- (10) **MP3/BT:** Allows you to control the volume of USB or bluetooth input.
- (11) **BASS:** Controls the bass tone of the amplifier output.
- (12) **TREBLE:** Controls the treble tone of the amplifier output.
- (13) **MASTER:** The master volume control to collectively control the sound level of all outputs.
- (14) **POWER:** Power switch ON/OFF.

## REAR PANEL

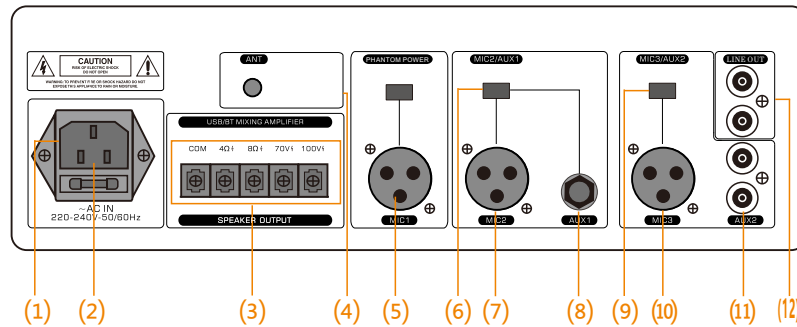

**(1) AC POWER INLET:** It accepts a standard 3-pin cable.

**(2) AC FUSE DRAWER:** Contains one main 1A fuse and one spare 1A fuse.

**(3) SPEAKER OUTPUT TERMINALS: COM, 4Ω, 8Ω, 70V, 100V**

It's only possible to use one output at the same time, connecting more than one may damage internal parts of the amplifier. Each of 100V, 70V, 4Ω and 8Ω terminals must work with COM.

**(4) BT ANTENNA JACK:** Using a special antenna allows for long-distance bluetooth connection up to 10 meters.

**(5) MIC1 JACK:** It accepts balanced XLR connection.

**(6) MIC2/AUX1 SELECTOR:** Switch between MIC2 and AUX1 input.

**(7) MIC2 JACK:** It accepts balanced XLR connection.

**(8) AUX1 JACK:** It accepts 6.35mm connection.

**(9) MIC3/AUX2 SELECTOR:** Switch between MIC3 and AUX2 input.

**(10) MIC3 JACK:** It accepts balanced XLR connection.

**(11) AUX2 JACK:** It accepts stereo "L" & "R" RCA connection, then converted to mono mode internally.

**(12) LINE OUT JACK:** Line outputs for additional amplifiers.

## SPECIFICATION

|                     |   |
|---------------------|---|
| <b>Model</b>        | <b>SP-60MB</b>  |
| Rated Power         | 60W   |
| Speaker Output Mode | Low impedance:4 & 8 ohms ( $\Omega$ )                     |
|                     | Voltage line:70V & 100V                                   |
| Frequency Response  | 60 Hz ~ 15k Hz ( $\pm$ 3 dB)                              |
| T.H.D               | <1% at 1kHz, 1/3 rated power                              |
| S/N                 | $\geq$ 75dB   |
| Tone Control        | BASS:100 Hz ( $\pm$ 10 dB) , TREBLE:10k Hz ( $\pm$ 10 dB) |
| Audio Input         | MIC,AUX, USB, BLUETOOTH                                   |
| Protection          | Short circuit,overload,high temperature                   |
| AC Fuse             | T1A   |
| Power Supply        | AC 220-240V- 50/60Hz                                      |
| Power Consumption   | 120W  |
| Power Cord          | (3 $\times$ 0.75 mm <sup>2</sup> ) $\times$ 1.5M          |
| Dimension           | 100(H) $\times$ 290(W) $\times$ 260(D) mm                 |
| Carton Size         | 160(H) $\times$ 330(W) $\times$ 320(D) mm                 |
| Net Weight          | 5.50kg  |
| Gross Weight        | 6.30kg  |

Specifications are typical; individual unit might vary.

Specifications are subject to change and improvement without prior notice.



CONNECTION ILLUSTRATION

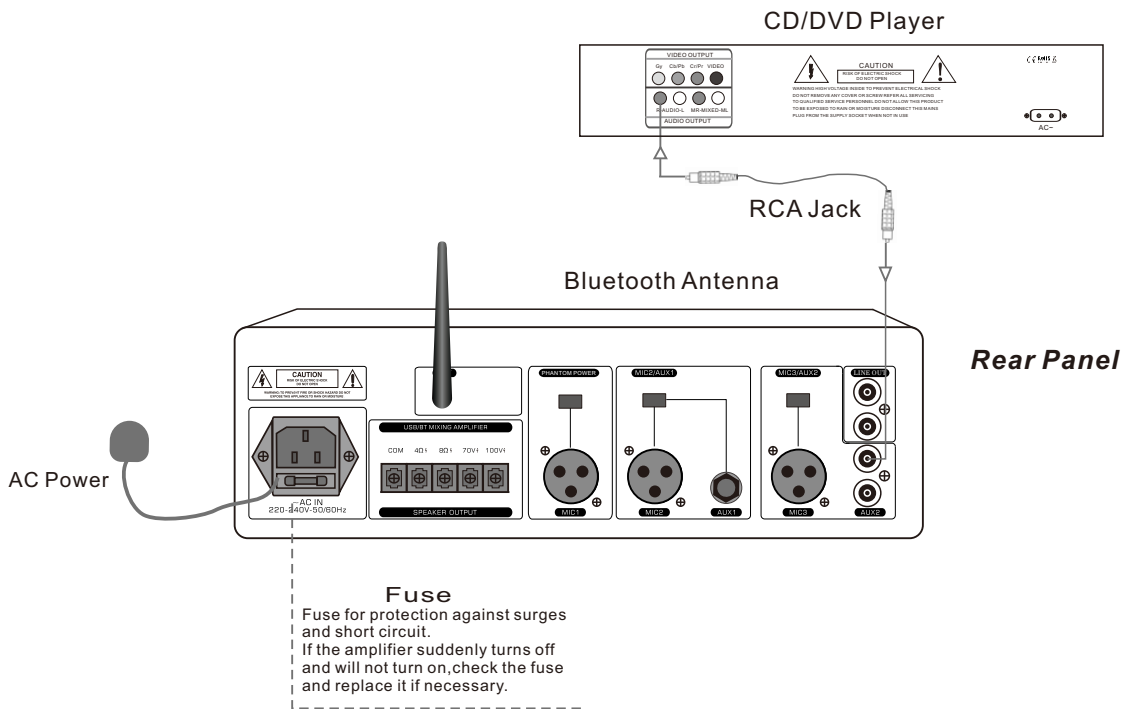
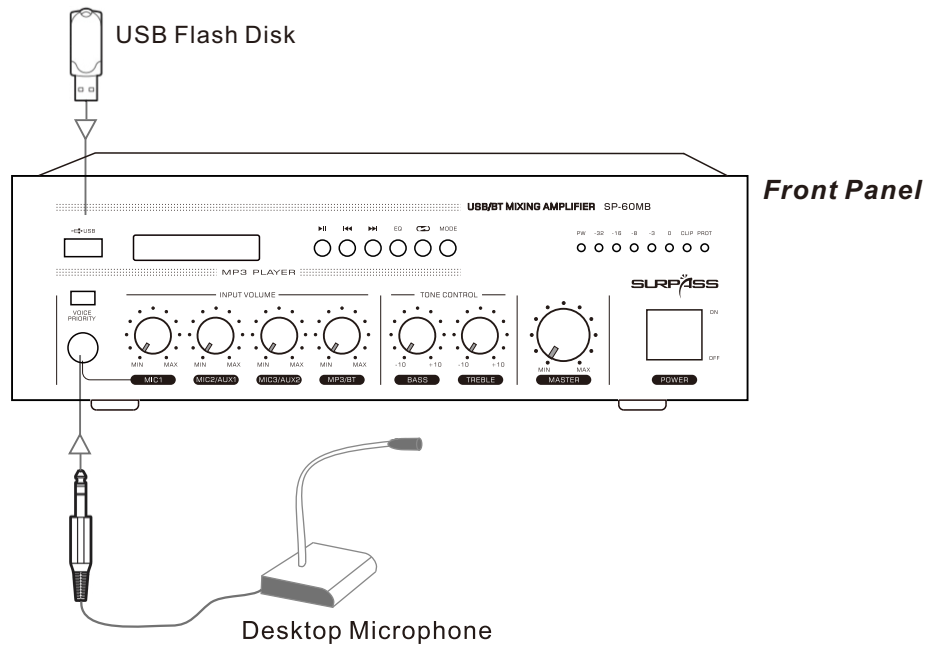

\* Notes:

Please refer to page 9 to 10 for details of connections of speakers.

Please refer to page 11 for details of Bluetooth operations.

**SPEAKER CONNECTION**

**Important Notes:**

This amplifier has different loudspeakers outputs of 100V,70V and low impedance 4Ω/8Ω. **It's only possible to use one output at the same time,connecting more than one may damage internal parts of the amplifier.Each of 100V,70V,4Ω and 8Ω terminals must work with COM. (common) terminal.**

**100V line output**

This system is most commonly used in for PA system. Only use 100 V line loudspeakers with transformers. All loudspeakers are wired in parallel and the sum of their power must not exceed the rated output power of the amplifier. **It is advisable not to load the amplifier at more than 70% of its rated output power when using music sources.**

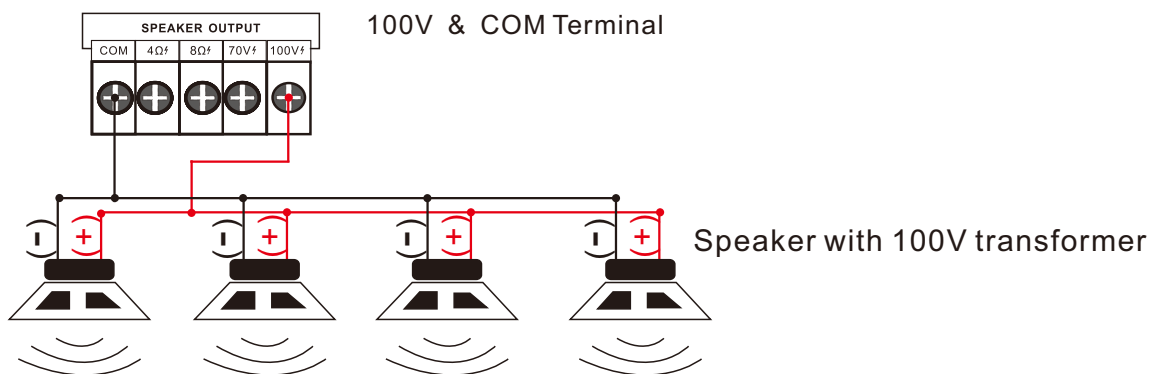

**70V line output**

This system is common in the USA, it operates on the same principles as 100 V line except that at rated output power the amplifier has 70V RMS on its output terminals.

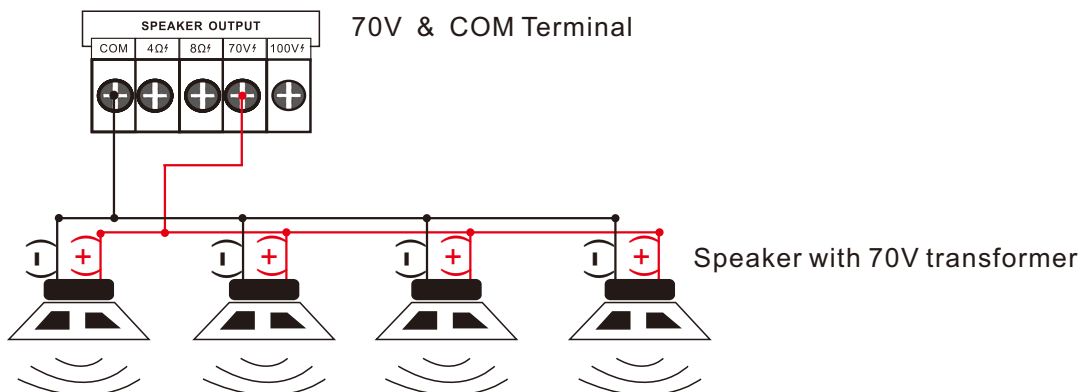

**4Ω & 8Ω low impedance output**

This output allows connection of low impedance loudspeakers without transformers, When two or more loudspeakers are used ensure that they are wired in such a way in Series, or in Parallel, or in Series & Parallel Combination that total load impedance remains at 4Ω or 8Ω.

**A. Connecting speakers in Parallel.**

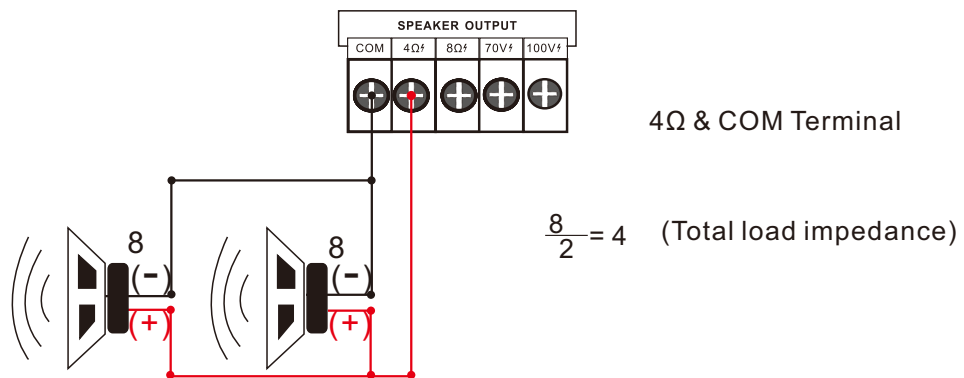

**B. Connecting speakers in Series & Parallel combination.**

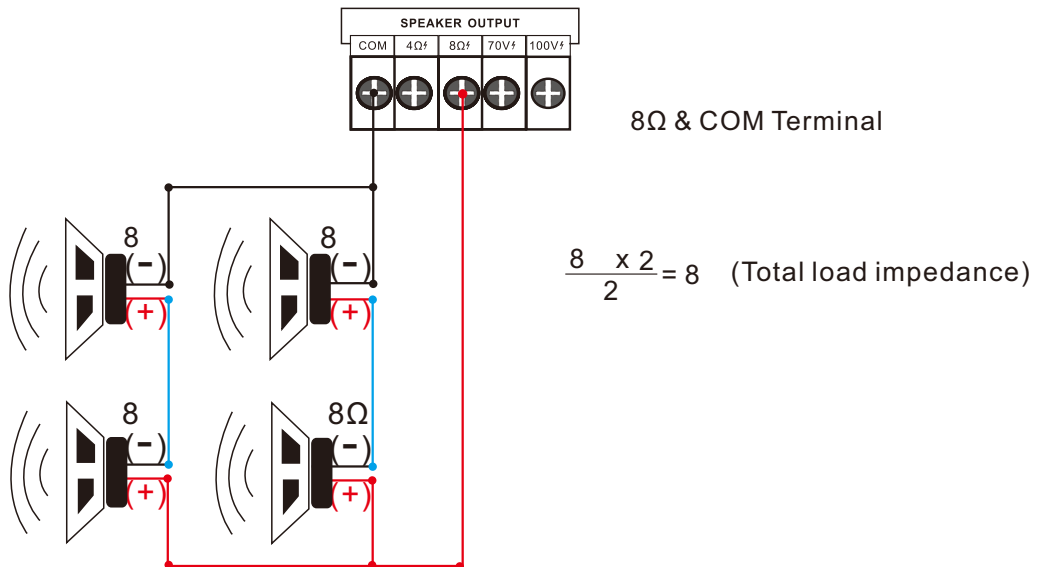

**BLUETOOTH OPERATIONS**

\*Note: The Bluetooth name of this amplifier is “**BGM SYSTEM**”

In order to enjoy music from a Bluetooth device on this amplifier, the Bluetooth device must first be paired with this amplifier.

Once the Bluetooth device has been paired, it does not need to be paired again.

1. Press the MODE button on the front panel of the amplifier to switch the input source to “Bluetooth”.

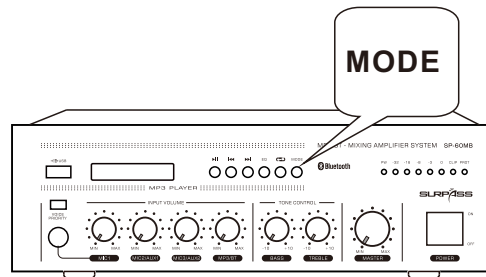

2. Activate the Bluetooth settings on your mobile device.



3. Select this unit “**BGM SYSTEM**” when its name appears in the list of devices displayed on the screen of your mobile device.

Perform the connection with your mobile device close to the unit (about 1 m).

At the end of the pairing, the name “BGM SYSTEM” appears on the paired list of your mobile device.

\*Note: Enter “1688” when the password is requested on the screen of the your mobile device.

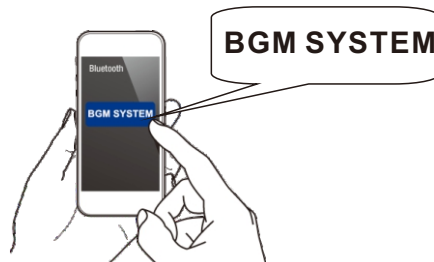

4. Play music using any app on your mobile device.

\* The next time the input source is switched to Bluetooth, this amplifier automatically connects to the last Bluetooth device that was connected.







**CAUTION:** Do not open the equipment cover arbitrarily, so as not to electric shock. Please contact the professionals to maintain if necessary.