

**SP-H10B/H10BR/H10BT**  
**Waterproof Horn Speaker 10W**



**Features:**

- Waterproof Horn Speaker 10W
- Excellent speech reproduction
- Stainless steel bracket and mounting hardware
- Suitable for exposed outdoor locations
- IP66 dust and water resistance

**Specifications:**

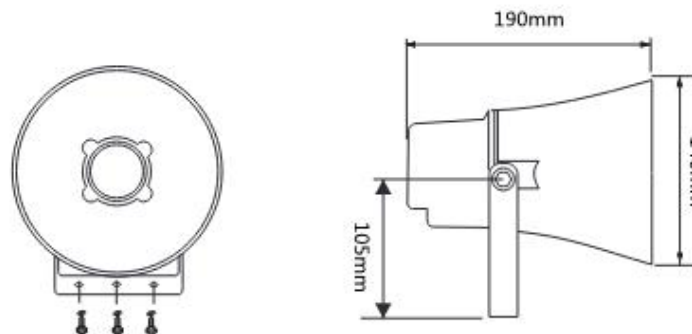

Model No.	<b>SP-H10B</b>	<b>SP-H10BR</b>	<b>SP-H10BT</b>
Power	10W/5W	10W	10W/5W/2.5W/1.25W/8Ω
Constant voltage input	100V	8Ω	100V/70V
Sensitivity	100±3dB		
Frequency Response	400Hz-8KHz		
Material	ABS Enclosure + Metal Bracket		
Color	Gray		
Waterproof rating	IP66		
Dimension	Φ140*190mm		
Net Weight	1.20KG		